











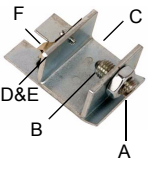















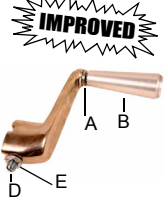





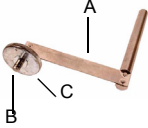

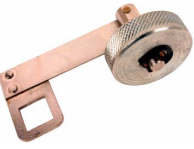











Replacement parts for : MULTI 1210, 1250OS, 1250W, 1250N, 1250DOM., 1215CD,

	PART #
	VARIABLE SPEED PULLEY 1250 O.S. - 1/2" Shaft P-1629 1250 N.S. - 5/8" Shaft P-1649
V-BELTS	
	35" Motor to printing head P-4904
	33" Pump to motor compound pulley P-1689
	32" Compound pulley to machine P-1688
	30" Compound pulley to machine P-1686
	26" To machine P-4903
	49" Conveyor drive P-1690
	34" New style pump to motor P-1695
	RATCHET PAWL ARM ASSEMBLY P-12979
SHEET SEPARATOR BRACKET ASSEMBLY	
	Complete P-12112 (A) Nut P-497 (B) Ball retainer P-1105 (C) Bracket P-12113 (D) Screw P-149 (E) Washer P-557 (F) Sheet separator P-12114
	SHEET SEPARATOR - 1360 P-13114
	SHEET SEPARATOR For TOKO 1218 P-128114
	CENTER BLOWER KIT Complete P-5065 (A) Center blower P-12128 (B) Thumb nut P-537 (C) Lockwasher P-624 (D) Washer P-566 (E) Bracket P-12164 (F) Retaining ring P-668 (G) Washer P-586 (H) Spring washer P-653 (I) Valve stem P-12069 (J) Hose - 27" P-5285
	HUB FOR P-13085 OSC ROLL P-13440
	SUCKER TUBE - 1650 P-16174
	O-RING For sucker tube P-5329
	SUCTION FEET Double stem P-12170 Single stem P-12990
	PILOT SCREW P-12104

	PART #
	COMPENSATING SUCKER TUBE ASSEMBLY <i>EXTENDS 1/4" FURTHER.</i> *** Excellent for running envelopes and heavy stock. 1250 (Set of 2 w / block) P-12259 1250 (Tube only) P-12966 1850 (Set of 3 tubes only) P-18990 1870 (Set of 4 tubes only) P-18170
	FLAT DISC SUCKER FOOT P-1552
	SUCKER FOOT For Multilith 1218 & for Toko 4700, 4750 P-5203
	PAWL LEVER For single sheet feed 1330, 1360, 1650, 1860, 1960 P-13563
	DRIVE LEVER ARM ASSEMBLY *** Made of 1/4" solid cast stock for longer life and durability. 1250 P-12927 1330, 1360 P-13927 1650 P-16927 1850 P-18927
	FEEDER LINKAGE DRIVE LEVER (near delivery) P-12732
	FEEDER PULLOUT ROLLER Roller with bearing P-12125 Bearing only P-1371 Spacer (on sides) P-12536 Spring P-12181
	SPRING For feeder pullout roller P-12386
	UPPER FEED ROLL HOLDER 1250 N.S. P-12115 1250 O.S. P-12274
	IMPROVED HAND CRANK ASSEMBLY *** Made of solid white brass which helps prevent stripping. Complete P-12955 (A) Stud P-36962 (B) Handle P-36961 (C) Spring lock (inside) P-36959 (D) Screw P-874 (E) Nut P-492 (F) Spring P-12909 (G) Steel ball P-755
	TABLE PAWL RELEASE LEVER 1250 P-12969 1330, 1360, 1650 P-13969
	(A) CONVEYOR DRIVE SPROCKETS - O.S. Front feed roller P-12555 Rear feed roller P-12559
	(B) TENSION SPROCKET P-12522
	TENSION ROLLER P-12425

2650, 2850, 4150, 4250, 1330, 1360, 1315CD, 1650, 1820, 1860, 1870, 1960

	PART #
	CONVEYOR TIMING PULLEY - N.S. -Conveyor roller P-4242 CONVEYOR TIMING PULLEY - N.S. -Front feed roller P-4257 CONVEYOR DRIVE PULLEY - N.S. -Rear feed roller P-4258
SKID ROLLER ASSEMBLY Works with P-12359 shown below.	
	Narrow wheel 1250 P-12434 (A) Arm P-12436 (B) Roller P-12454 (C) C-ring P-680 Wide wheel 1850 P-18434 (A) Arm P-12436 (B) Roller P-12532 (C) C-ring P-680 (D) Bushing (comes with Roller P-12532) P-799
	THUMB SCREW P-311
	SKID WHEEL HOLDER P-12359
	SKID ROLLER ASSEMBLY For old design skid wheels that uses posts. Complete 1250 P-12501 Arm only P-14492 Wheel only P-12532 Bushing (included w/ P-12532) P-799 C-ring P-680
	CONVEYOR PAPER RETAINER P-12433
	GUIDE ASSEMBLY - 1360 P-13403
	CONVEYOR FEED TAPES Regular plastic P-4957 Special cloth for easier feeding P-4955
	PAPER GUIDE SPRING 1250 P-12924 SCREW P-191
	PAPER GUIDE SPRING - 1850 & 1860 P-18527
	TAPE BAR P-12708
	FEELER FINGER P-12141
	PILOT SCREW P-3073
	EJECTOR PIN BAR - Universal for old & new style. 1250 (7 Pin) P-12249

	PART #
	REGISTER BAR ASSEMBLY (Complete) (A) Support rod P-13703 (B) Register bar with scale P-13483 (C) Screw P-13359 (D) Lockwasher P-225 (E) Washer (comp. assm. takes 2) P-635 (F) Spacer P-1811 (G) Adjusting block (comp. assm. takes 2) P-1415 (H) Thumb screw (comp. assm. takes 3) P-13497 (I) Skid roller and block assm. - short P-7220 (J) Set screw (not shown) P-18 (K) Skid roller and block assm. - long P-13434 (L) Thumb screw P-1807 (M) Brass plug (short) (not shown) P-11795 (N) Retaining ring (not shown) P-698 (O) Brass plug (long) for thumb screw "H" P-4788
	SPECIAL MICRO ADJUSTING NUT & STOP For upper feed roll adjustment P-12135 ... NO TOOL NEEDED FOR FAST & EASY ADJUSTMENT!
	PAPER FEED FRAME LEVERS 1250 Old design (straight, no tab) P-12165 1250 O.S. & L.W. (straight, with tab) P-12156 1250 N & DOM. (bent, with tab) P-12151 1650 (straight) P-16156 1650 (bent) P-16151
	CAM LEVER 1250 P-12155 1650 P-16155
	FEED FRAME ROLLER 1250 P-12157 1330, 1360, 1650 P-13157
	FOUR FINGER SHAFT ASSEMBLY -Complete 1250 New style (pyramid cam - no notch) P-12393 -Complete 1250 Domestic (tear drop cam) P-12387 -Complete 1250 M / MG (notched pyramid cam & tear drop cam) P-12381
	THREE FINGER SHAFT ASSEMBLY -Complete 1250 Old style P-12388
	PAPER HOLD ATTACHMENT -Complete 1250 P-12840
	IMPRESSION GRIPPER SHAFT & ARM ASS'Y. Complete P-12203 Arm assembly P-12207 Shaft only P-12205 Arm only P-12197
	IMPRESSION CYLINDER ADJUSTING SEGMENT P-12733

THIS IS JUST A SAMPLE OF OUR TOTAL INVENTORY

Replacement parts for : MULTI 1210, 1250OS, 1250W, 1250N, 1250DOM., 1215CD,

	PART #
 <p>IMPRESSION GRIPPER HOLDER ASSEMBLY Complete P-12182 (A) Finger O.S. P-12245 (A) Finger N.S. P-12237 (B) Holder P-12189 (C) Screw (not shown) P-12187 (D) Screw P-96 (E) Washer (not shown) P-586</p>	
 <p>BUSHING For impression cylinder adjustment 1850 Non-op. side P-18400</p>	
 <p>CYLINDER GEARS Master (plate) P-12313 Blanket P-12214 Impression P-12191 ... All gears are hardened for longer life.</p>	
 <p>BLANKET CYLINDER SHAFTS 1250 (.750 Dia.) P-12290 1250 (.010 Oversized dia.) P-12302 1330, 1360, 1650 (.1.125 Dia.) P-13290 1330, 1360, 1650 (.030 Oversized dia.) P-13302 1850 (1.125 Dia.) P-18290 1850 (.030 Oversized dia.) P-18302</p>	
 <p>CAM BAND - 1250 O.S. & N.S. For blanket cylinder P-12178</p>	
 <p>MASTER CYLINDER ADJUSTING WRENCH 1250 O.S. P-12266 1250 N.S. P-12236 1360 (13" clamps) P-13266 1360 (16-1/2" clamps) P-13236 1960 P-19236</p>	
 <p>MASTER CYLINDER CLAMP LOCK LINK 1330, 1360, 1650 P-13299</p>	
 <p>BLANKET CYLINDER CLAMP KIT Complete (Trailing 11x17) P-14258 (A) Screw P-12204 (B) Spring P-12390 (C) Pin bar P-12922 (D) Bracket P-14003 (E) Nut bar P-14004 (F) Screw P-12921</p>	
 <p>MASTER CYLINDER UPGRADE KIT 1650 P-13385</p>	
 <p>ACTUATING TOOL For plate cylinder latch 1330, 1360, 1650 P-5888</p>	
 <p>MASTER CYLINDER HOLD DOWN BRACKET - 1360, 1650 P-13357</p>	

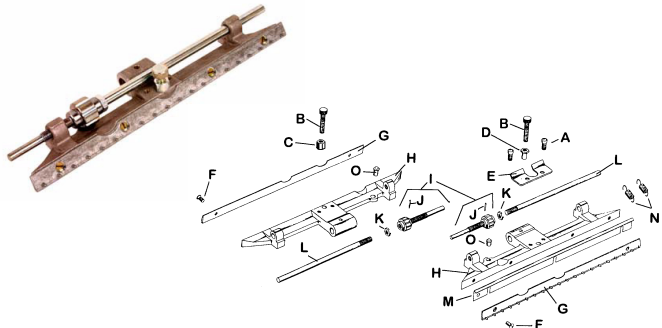
	PART #
 <p>CLAMP COMPLETE - Trail End P-13790 (A) R.H. Bracket P-13377 (B) Clamp P-13389 (C) Special Nut P-11991 (D) Retaining Ring P-666 (E) Spring P-13724 (F) L.H. Bracket P-13379 (G) Round Head Screw P-194 (H) Lockwasher P-623 (I) Pin Bar with Lever P-13323 (J) Spring-Extension P-13309 (K) Thumb Screw P-11783 (L) Support P-16357 (M) Flat Head Screw P-652</p>	
 <p>1250 (10 X 15) MASTER CYLINDER ASSEMBLIES Lead Edge - complete P-12788 (A) Screw P-159 (B) Thumb screw P-1095 (C) Nut (used on P-12788 only) P-1898 (D) Nut (used on P-12790 only) P-12796 (E) Handle (used on P-12790 only) P-12761 (F) Screw P-12770 (G) Pin bar (18 point*) P-12760 (H) Clamp only - not sold alone ----- (I) Adjusting screw P-12812 (J) Taper pin P-421 (K) Nut P-497 (L) Stem P-12793 (M) Retainer (used on P-12790 only) P-12797 (N) Spring (used on P-12790 only) P-12762</p>	



... MADE OF ALLOY STEEL DIECAST FOR LONGER LIFE & GREATER DURABILITY.

PIN BAR CLAMP Master cylinder (10 X 15)
 18 Point - 10" long P-12760

CLAMP Blanket cylinder
 17 Point - 9-3/4" long P-12922

2650, 2850, 4150, 4250, 1330, 1360, 1315CD, 1650, 1820, 1860, 1870, 1960

PART #

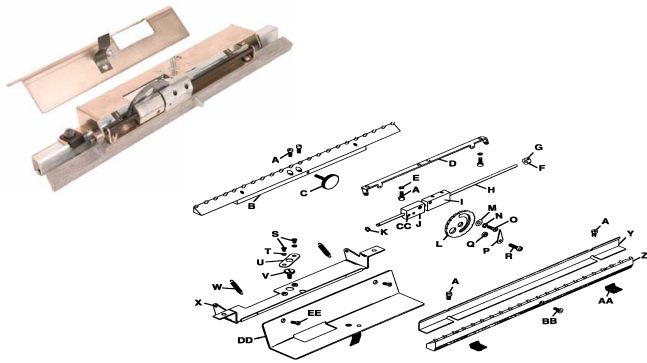

16-1/2" ANGULAR ADJUSTING CLAMP ASSEMBLY

Complete (1250)	P-12702
Complete (1360, 1650)	P-13702
Sub assy. - items (A) - (CC) (1250)	P-12717
Sub assy. - items (A) - (CC) (1360, 1650)	P-13717
(A) Screw	P-161
(B) Pin bar (tail) - 22 point (1250)	P-12746
(B1) Pin bar (tail) - 11 point (1360, 1650)	P-13746
(B2) Pin bar (tail) - 13 point (1360, 1650)	P-13659
(C) Thumb screw	P-1067
(D) Bracket	P-12729
(E) Lockwasher	P-624
(F) Collar	P-927
(G) Set screw	P-3
(H) Shaft	P-12726
(I) Lateral adjusting block	P-12736
(J) Adjusting block	P-12734
(K) Retaining ring	P-664
(L) Adjusting wheel	P-12744
(M) Washer	P-1887
(N) Spring washer	P-650
(O) Shoulder screw	P-8090
(P) Pointer	P-12745
(Q) Spacer cam	P-1402
(R) Screw	P-172
(S) Screw	P-191
(T) Lockwasher	P-623
(U) Retainer	P-12738
(V) Shoulder screw	P-8089
(W) Spring	P-12724
(X) Bracket (1250)	P-12716
(Y) Lead retainer	P-12751
(Z) Pin bar - (lead) - 22 point (1250)	P-12739
(Z1) Pin bar - (lead) - 13 point (1360, 1650)	P-13739
(Z2) Pin bar - (lead) - 11 point (1360, 1650)	P-13652
(AA) Clip nut	P-12749
(BB) Screw	P-10323
(CC) Set screw	P-1089
(DD) Shelf	P-12705
(DD) Shelf (1360, 1650)	P-13705
(EE) Screw	P-12375



PLASTIC BOTTLE RECEPTACLE VALVE
P-12347



WATER FOUNTAIN HOSE
1250, 1850 O.S. (10-1/2") P-1189
1850 N.S. (19") P-1181

BOTTLE, CAP & ADAPTER 1250 N.S., 1360, 1850, 1962
(Bottle sits in black plastic receptacle on side of water frame)

1 Quart assembly	P-1912
2 Quart assembly	P-1921



BOTTLE, CAP & ADAPTER 1250 O.S.
(Bottle sits directly in water fountain)

1 Quart assembly	P-1911
2 Quart assembly	P-1920

PART #



(A) **WATER DUCTOR PIVOT** - 1250 N.S., LW (11X17)

3/8" Bore P-12322

(A) **WATER DUCTOR PIVOT** - 1250 O.S. (10 X 15)

7/16" Bore P-12535



SCREW - O.S. & N.S. P-84

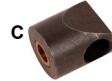

(B) **EQUALIZER PIVOT** - 1330, 1360

P-13322

(C) **PIVOT HOUSING ASSEMBLY** - 1330, 1360

P-13535



DRIVE DISC For water form roller
P-12419



PIN ASSEMBLY For water fountain roller

Short 1-7/8" shaft P-12688
Medium 2-1/8" shaft P-12687
Long 3-3/16" shaft P-12691



COLLAR (For pin assembly listed above)

1/2" for short pin P-12371

7/8" for long/medium pin P-12370



SHAFT For water fountain roller
P-12402



DRIVE COLLAR For Water fountain roller

... *Made of steel for longer life.*
For non-operators side P-12417

SCREW P-840



PAWL - Water / Ink ratchet P-12268
(A) 1250



PAWL - Water / Ink ratchet
(B) 1330, 1360, 1650, 1850, 1960
P-13268

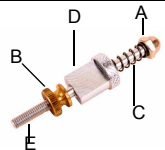

RETAINER For water oscillating roller

(A) Hex cap nut P-470
(B) Thumb nut P-538
(C) Spring P-12413
(D) Retainer P-12560
(E) Stud (stem) P-7053



BEARINGS For "Multi Flow" Water oscillator.

Operators side P-5770
Non-operators side P-5775



BEARING SHIELD (need 2)

For lower ink form roller on 1820 second color head
P-1820000 6.00



FORM ROLLER KNOBS

Upper ink form P-12489
Lower ink form P-12491
Water form P-12405

SET SCREW (all knobs) P-8









SEPARATING CAM For ink form roller



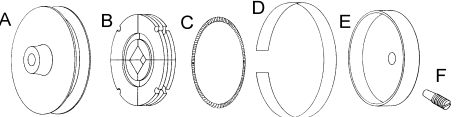



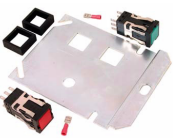

1250 O.S. (10 X 15) P-12864
1250 N.S. (11 X 17) P-12451
TAPER PIN O.S. P-441
TAPER PIN N.S. P-439

Replacement parts for : MULTI 1210, 1250OS, 1250W, 1250N, 1250DOM., 1215CD,

	PART #
	INK IDLER GEAR - Bushing included 1250 O.S. (10 X 15) P-12455 1250 N.S. (11 X 17) P-12446
	BUSHING P-1236
	INK IDLER GEAR - Does not use bushing. 1360, 1650 P-13457
	DOG For oscillating rollers (A) Water P-12428 (B) Ink P-12463
	WORM For ink & water oscillating rollers P-12464
	HOLD DOWN SCREW P-12494
	IDLER ROLLER BUSHING - 1650 P-11411
	ROLLER SUPPORT 1330, 1360 P-13915
	INK & WATER DUCTOR ARM 1250 N.S. (steel) P-12321 INK & WATER DUCTOR LATCH 1250 N.S. P-12338
	1) INK & WATER DUCTOR ARM 1250 O.S. (Brass) P-12607
	2) INK DUCTOR LATCH No bend 1250 O.S. (L.H. & R.H.) P-12546 1850 P-18546
	3) INK DUCTOR LATCH - With bend 1250 W (R.H.) P-14546 1250 W (L.H.) P-14338
	4) RIGHT HAND SPRING - Ink & water ductor latch 1250 O.S. (10 X 15) P-12575 1250 N.S. (11 X 17) P-12336
	5) LEFT HAND SPRING - Ink & water ductor latch 1250 O.S. (10 X 15) P-12551 1250 N.S. (11 X 17) P-12331
	INK & WATER RATCHET WHEEL 1250, 1850 P-12239 1960 P-19239
	SNUBBER - Ink & water ratchet lever P-7058
	INK FOUNTAIN ASSEMBLY - 1250 O.S. & N.S. *** <i>Designed with replaceable end caps & deeper well for 50% more ink capacity.</i> Complete P-12778 Fountain only P-12789 Thumb screw (14 total) P-1570 Wire P-35084 Clamp P-12082 Screw for clamp P-12907 Blade 1250 (10-1/4" X 1-3/4") P-12079 Blade 1250 (10-1/4" X 3") P-12233
	INK FOUNTAIN BLADE 1650 P-16233 1960 P-19079 Blade 1850 only P-18079

	PART #
	COMPOUND PULLEY P-4259
	CLUTCH WEIGHT - 1360 P-13593
	CLUTCH PULLEY ASSEMBLY
	
	Complete 1250 P-14001 Complete 1850 P-18001 (A) Pulley only 1250 P-12587 (A) Pulley only 1850 P-18587 (B) Clutch shoe (set of 4) P-12593 (C) Spring P-12591 (D) Liner P-5061 (E) Clutch drum 1250 P-12617 (E) Clutch drum 1850 P-18617 (F) Pilot screw P-7069
	INK WASH UP ATTACHMENT *** <i>Universal for old & new style.</i> 1250 O.S., W, LW (10 X 15 & 11 X 17) P-12773
	WASH UP BLADE P-5030 *Fits our wash up attachment only.
	OLD STYLE DRIVE SHAFT ASSEMBLY Complete P-12835 (A) Pinion gear - (black-stamped "O") P-12854 (B) Taper pin P-435 (C) Drive shaft P-12869
	Complete P-12837 (A) Pinion gear - (silver) P-12865 (B) Taper pin P-435 (C) Drive shaft (only) P-12869
	PILOT SCREW For pulley - both styles P-8068
	NEW STYLE DRIVE SHAFT ASSEMBLY With long shank gear. For use with hardened cylinder gears. Complete P-12577 (A) New style gear P-12581 (B) Taper pin P-435 (C) Drive shaft P-12583
	PILOT SCREW For pulley P-8067
	DRIVE SHAFT ASSEMBLY - 1360, 1650 Complete P-13837 (A) Pinion gear P-13581 (B) Taper pin P-435 (C) Drive shaft P-13869

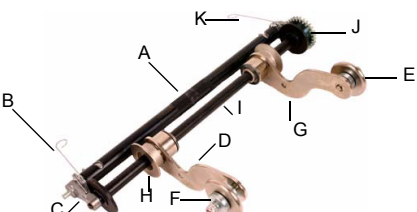
2650, 2850, 4150, 4250, 1330, 1360, 1315CD, 1650, 1820, 1860, 1870, 1960

	PART #
 <p>SWITCH ASSEMBLY Complete P-12566 Start (green) 1250 N.S. P-12829 Stop (red) 1250 N.S. P-4062</p>	
 <p>SWITCH REPLACEMENT KIT 1330, 1360 Consists of: 1 ea. stop switch (red) & start switch (green), 1 mounting plate, 2 switch holders, 10 wire terminals. Also includes installation instructions. P-9828</p>	
 <p>ALTERNATE ACTION SWITCH 1960 P-4060</p>	
 <p>PUMP SWITCH 1330, 1360 P-4470</p>	
<p>1</p>  <p>(1) TOGGLE SWITCH For drive motor & pump (includes screws) 1250 O.S. P-12305</p>	
<p>2</p>  <p>(2) MOMENTARY TOGGLE SWITCH 1250 L.W. P-4056</p>	
 <p>COUNTER With bracket & arm P-12996 With bracket & no arm P-12954 Counter only 1250N, 1360 P-12952</p> <p>COUNTER ARM ONLY P-12942</p>	
 <p>"QUICK CHANGE" UPPER EJECTOR ROLLER ASSEMBLY *** Adjustable, gear driven with a knurled shaft for quick removal and easy access.</p> <p>Complete 1250 N.S. P-12616 (A) Rod assembly P-12558 (B) Spring P-12604 (C) Arm assembly L.H. & R.H. P-12584 (D) Arm assembly R.H. P-12612 (E) Roll assembly P-12600 (F) Roller P-1444 (G) Arm assembly L.H. P-12611 (H) Roller P-12621 (I) Shaft & gear assembly P-12782 (J) Wheel P-12590 (K) Spring P-12618</p>	
 <p>STRIPPER FINGER - 1650 CD (1615) P-162281</p>	
 <p>BACK JOGGER LEVER ASSEMBLY 1850 CD (1815) P-181590</p>	

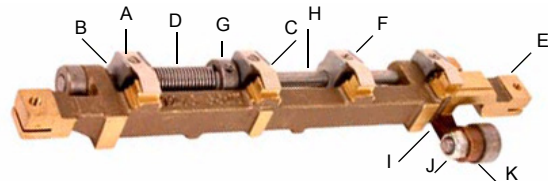
	PART #
 <p>GRIPPER BAR CHAINS 1250 (53-3/4" long X 1/2" wide) P-121100 1850 (54-1/4" long X 1/2" wide) P-181100 Carrier link - 1250, 1850 P-9406 For Press Specialties chain delivery - N.S. (51-1/4" long X 1/2" wide) P-8944 For Press Specialties chain delivery - O.S. (50-3/4" long X 7/16" wide) P-8933 Gripper chain - TOKO 1218 P-8971 Carrier link - TOKO 1218 P-8736</p>	
 <p>GRIPPER BAR ASSEMBLY (WITH BRASS COLORED ANVIL) *** MADE OF YELLOW BRASS FOR HIGHER TENSIL STRENGTH.</p> <p>Complete 1250 P-120990 Complete 1330, 1360 P-130990 Complete 1850 P-180990 Complete 1960 P-190990 (A) Finger P-121020 (B) Screw P-12187 (C) Holder P-121061 (D) Spring P-121080 (E) Anvil only 1250 P-121090 (E) Anvil only 1330, 1360 P-131090 (E) Anvil only 1850 P-181090 (E) Anvil only 1960 P-191090 (F) Screw P-44 (G) Locking collar P-734 (H) Shaft assembly 1250, 1330, 1360 P-121010 (H) Shaft assembly 1850 P-181010 (I) Stud P-4600 (J) Nut P-522 (K) Cam roller P-1447</p>	
<p>GRIPPER BAR REPAIR KIT Consists of the most commonly replaceable parts on your gripper bar assembly. (Less anvil & shaft) For Multilith style gripper bars only</p> <p>1250, 1360 P-30733</p>	
<p>GRIPPER BAR REPAIR KITS For Press Specialties Consists of the most commonly replaceable parts on your gripper bar assembly. (Less anvil & shaft where noted)</p> <p>1217 (4 finger)* P-30745 1217, 1250 (5 finger)* P-30746 1250 (4 finger)** P-30747 1252 * P-30748</p> <p>* does not come with shaft or anvil. ** comes with shaft but no anvil.</p>	
<p>*** ELIMINATE COSTLY DOWNTIME WITH YOUR OWN EMERGENCY KIT FOR YOUR MODEL PRESS.</p> <p>REPAIR KITS FOR ALL MULTILITHS</p> <p>Master kit P-1776 - 435 pcs. Junior kit P-30328 - 217 pcs. Nut kit P-1772 - 60 pcs. Screw kit P-1773 - 62 pcs. Pin kit P-1774 - 86 pcs. Spring kit P-1775 - 85 pcs. Washer & ring kit P-1777 - 136 pcs.</p>	

THIS IS JUST A SAMPLE OF OUR TOTAL INVENTORY